

# MC 15/50 kanalhjul avloppspump GEN1

Artikelnr	Beteckning	Beskrivning
101977	MC 15/50:1,1/3x400/G65	MCM 15/50 kanalhjul avloppspump GEN1

Installation		Övrigt	
Styrning	Nivåvipa	Max Tryck	16 mVp
Anslutning	G65 inv	Max Flöde	800 l/min

Elektrisk Data	
Effekt	1,10 kW
Märkström	3,2 A
Spänning	3x400



## Pedrollo MC Kanalhjul Avloppspump

PEDROLLO MC är en serie högeffektiva, dränkbara avloppspumpar med konstruktion i gjutjärn. Pumpen har inbyggd vipa för automatisk start och stopp.

Kanalhjul säkerställer problemfri hantering av svart-, BDT-, grå- och dränvatten med fritt genomlopp på upp till 50 mm som tillåter passage av stora partiklar, samtidigt som man bibehåller hög effektivitet.

MC-serien lämpar sig väl till pumpning från dräneringsbrunn, parkeringshus och andra avloppsapplikationer som kräver större flöde.

Dubbla axeltätning i kiselkarbid säkerställer en lång livslängd.

- Stort genomlopp – Stora partiklar.
- Genomgående konstruktion i gjutjärn.
- Tillverkad i Italien.

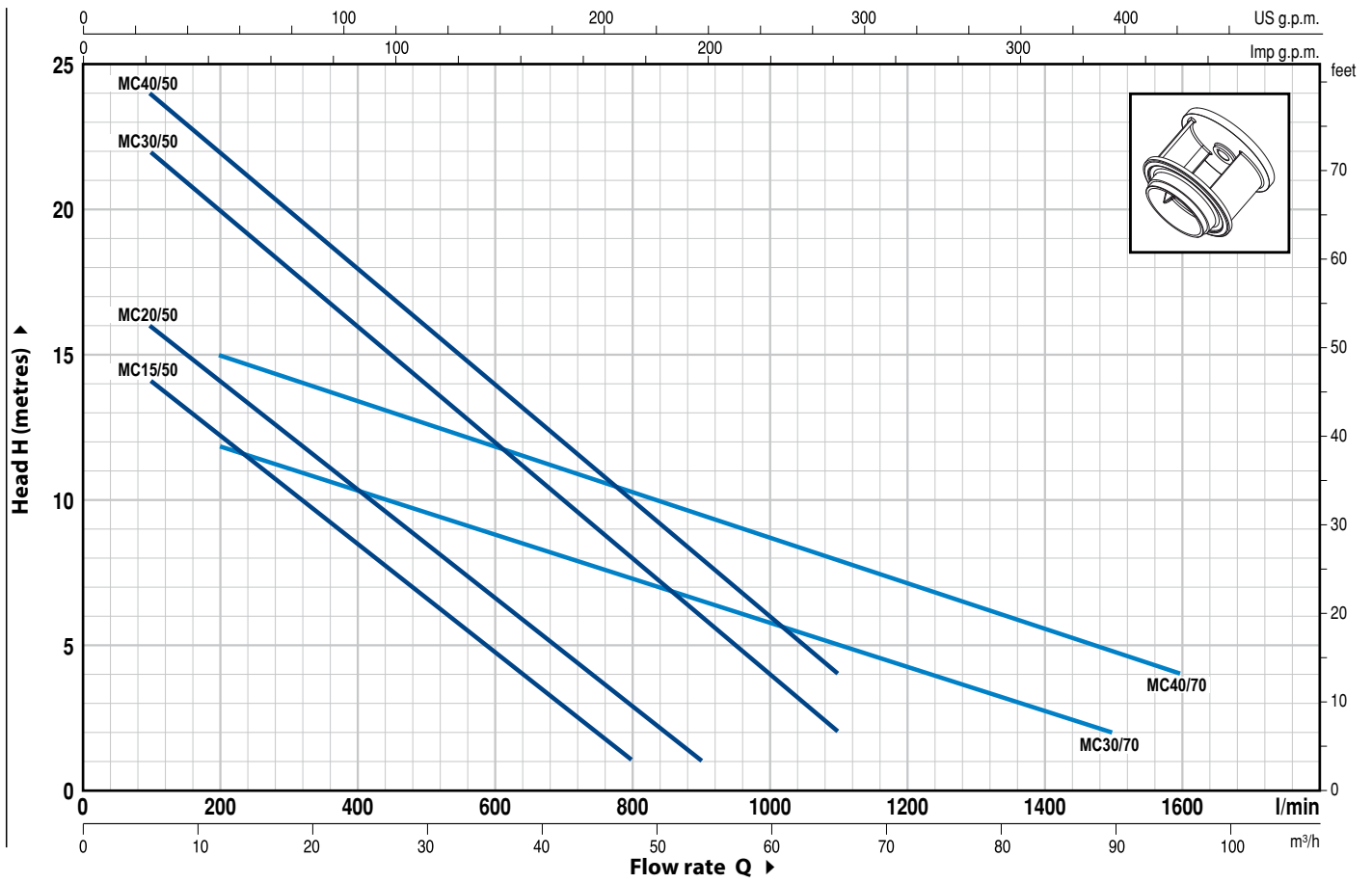

MODEL		POWER		Q	Flow rate																
Single-phase	Three-phase	kW	HP		m³/h	0	6	12	18	24	30	36	42	48	54	60	66	72	84	96	
				l/min	0	100	200	300	400	500	600	700	800	900	1000	1100	1200	1400	1600		
MCm 15/50	MC 15/50	1.1	1.5	H metres	16	14	12.5	10.5	8.5	6.5	4.5	3	1								
MCm 20/50	MC 20/50	1.5	2		18	16	14	12.5	10.5	8.5	6.5	5	3	1							
MCm 30/50	MC 30/50	2.2	3		24	22	20	18	16	14	12	10	8	6	4	2					
-	MC 40/50	3	4		25	24	22	20	18	16	14	12	10	8	6	4					
MCm 30/70	MC 30/70	2.2	3		13	-	12	11	10.5	9.5	8.5	8	7.5	6.5	6	5	4.5	3	2		
-	MC 40/70	3	4		17	-	15	14	13.5	12.5	12	11	10.5	9.5	8.5	8	7	5.5	4		

Q = Flow rate H = Total manometric head

Tolerance of characteristic curves in compliance with EN ISO 9906 App. A.

POS.	COMPONENT	CONSTRUCTION CHARACTERISTICS				
1	<b>PUMP BODY</b>	Cast iron, with threaded port in compliance with ISO 228/1				
2	<b>BASE</b>	Stainless steel AISI 304				
3	<b>IMPELLER</b>	Stainless steel AISI 304 DOUBLE-CHANNEL type				
4	<b>MOTOR CASING</b>	Cast iron				
5	<b>MOTOR CASING PLATE</b>	Cast iron				
6	<b>MOTOR SHAFT</b>	Stainless steel AISI 431				
7	<b>TWO MECHANICAL SEALS SEPARATED BY AN OIL CHAMBER</b>					
	<b>Seal</b>	<b>Shaft</b>	<b>Position</b>	<b>Materials</b>		
	<b>Model</b>	<b>Diameter</b>		<b>Stationary ring</b>	<b>Rotational ring</b>	<b>Elastomer</b>
	<b>STA-20</b>	Ø 20 mm	Motor side	Ceramic	Graphite	NBR
	<b>STA-19</b>	Ø 19 mm	Pump side	Silicon carbide	Silicon carbide	NBR
8	<b>BEARINGS</b>	<b>6304 ZZ - C3 / 6304 ZZ - C3</b>				
9	<b>CAPACITOR</b>					
	<b>Pump</b>	<b>Capacitance</b>				
	<i>Single-phase</i>	<i>(230 V or 240 V)</i>				
	<b>MCm 15/50</b>	<b>31.5 µF 450 VL</b>				
	<b>MCm 20/50</b>	<b>50 µF 450 VL</b>				
	<b>MCm 30/50</b>	<b>60 µF 450 VL</b>				
	<b>MCm 30/70</b>	<b>60 µF 450 VL</b>				
10	<b>ELECTRIC MOTOR</b>					
	<b>MCm 15-20:</b> single-phase 230 V - 50 Hz with thermal overload protector built-in to the winding					
	⇒ <b>MCm 30:</b> single-phase 230 V - 50 Hz with thermal overload protector built-in to the winding to be connected to the control box					
	⇒ <b>MC:</b> three-phase 400 V - 50 Hz. with thermal overload protector built-in to the winding to be connected to the control box					
	– Insulation: F class					
	– Protection: IP X8					
11	<b>POWER CABLE</b>					
	<b>10 metre</b> long "H07 RN-F" cable					
12	<b>CONTROL BOX for MCm 15-20</b>					
	(only for single-phase versions)					
	Complete with capacitor and manual reset motor protector					
13	<b>CONTROL BOX for MCm 30</b>					
	(only for single-phase versions)					
	<b>QES 300 MONO</b> series					
14	<b>FLOAT SWITCH</b>					
	(only for single-phase versions)					

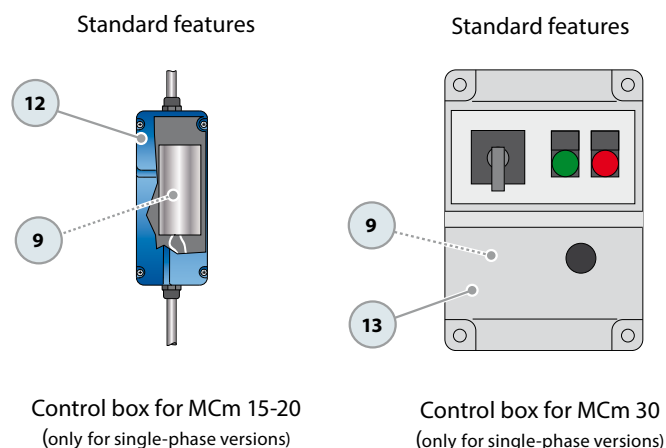
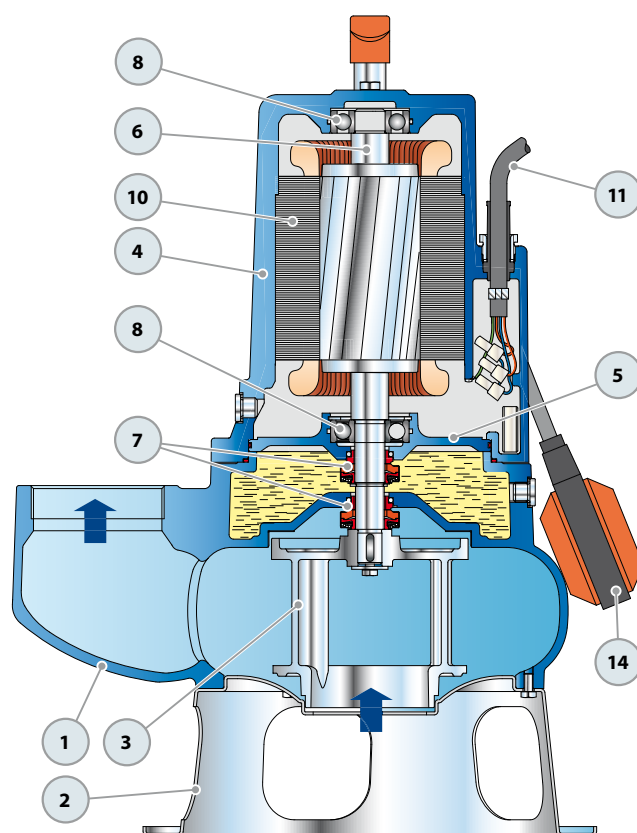

**DIMENSIONS AND WEIGHT**

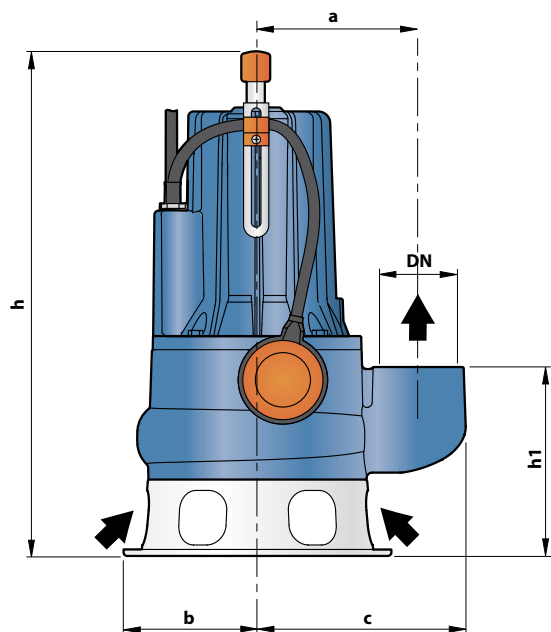

Typical installation

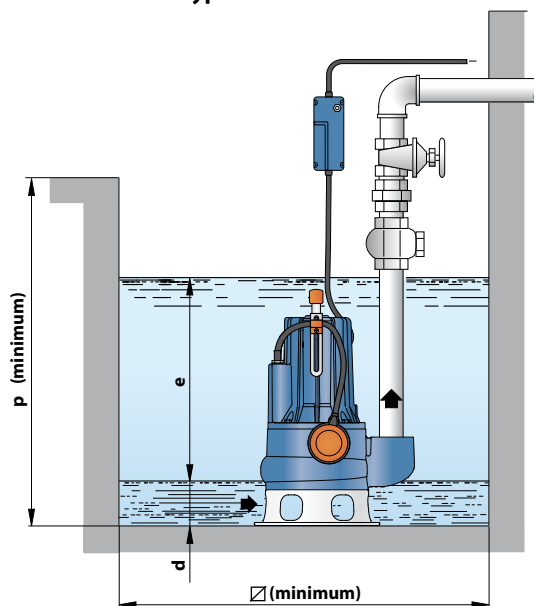

MODEL		PORT DN	solids passage	DIMENSIONS mm									kg	
Single-phase	Three-phase			a	b	c	h	h1	d	e	p	Ø	1~	3~
MCm 15/50	MC 15/50	2½"	Ø 50 mm	162	135	210	509	191	75	variable	800	800	36.7	35.4
MCm 20/50	MC 20/50						522/509						37.7	36.4
MCm 30/50	MC 30/50						522						41.9	38.6
-	MC 40/50												-	42.2
MCm 30/70	MC 30/70	3"	Ø 70 mm	180	150	237	562/548	233	85				45.0	41.7
-	MC 40/70						562						-	45.3

**ABSORPTION**

MODEL	VOLTAGE (single-phase)	
Single-phase	230 V	240 V
MCm 15/50	9.0 A	9.0 A
MCm 20/50	10.5 A	10.5 A
MCm 30/50	15.2 A	15.2 A
MCm 30/70	15.2 A	15.2 A

MODEL	VOLTAGE (three-phase)					
Three-phase	230 V	400 V	690 V	240 V	415 V	720 V
MC 15/50	5.5 A	3.2 A	1.8 A	5.5 A	3.2 A	1.8 A
MC 20/50	7.4 A	4.3 A	2.5 A	7.4 A	4.3 A	2.5 A
MC 30/50	9.9 A	5.7 A	3.3 A	9.9 A	5.7 A	3.3 A
MC 40/50	13.5 A	7.8 A	4.5 A	13.5 A	7.8 A	4.5 A
MC 30/70	10.2 A	5.9 A	3.4 A	10.2 A	5.9 A	3.4 A
MC 40/70	13.5 A	7.8 A	4.5 A	13.5 A	7.8 A	4.5 A